

# Kubota V3300

## V3-Serie

Importeur Kubota  
 Motoren Nederland:  
 Prins Maasdijk  
 Tuindersweg 37  
 2676BD Maasdijk  
 Tel. 0174-516240  
 Fax 0174-518142  
 info@prinsmaasdijk.nl  
 www.prinsmaasdijk.nl



### Specificaties

Model	V3300 (low fan)	
Emissie reglement	Stage II / Tier 2	
Type motor	Verticale watergekoelde 4-takt diesel	
Aantal cilinders	4	
Boring	mm	98
Slag	mm	110
Cilinderinhoud	L	3.318
Inspuitsysteem	IDI	
Inlaatsysteem	Atmosferisch	
Max toerental	rpm	2600(Belast)
Uitgaand vermogen		
Netto intermitterend	kW (pk)	50.7 (68.0)
Continu vermogen	kW (pk)	44.1 (59.1)
Draairichting	Tegen de klok in (vliegwielzijde)	
Droog gewicht	kg	241

### Afmetingen

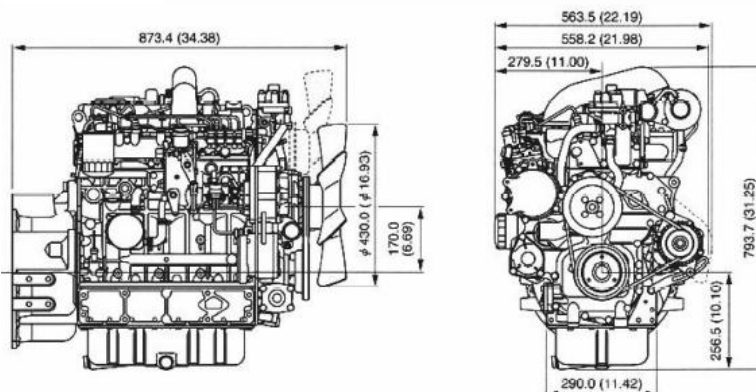

De specificaties van de motor kunnen aan wijzigingen onderhevig zijn.

### Motorkarakteristieken (bruto)

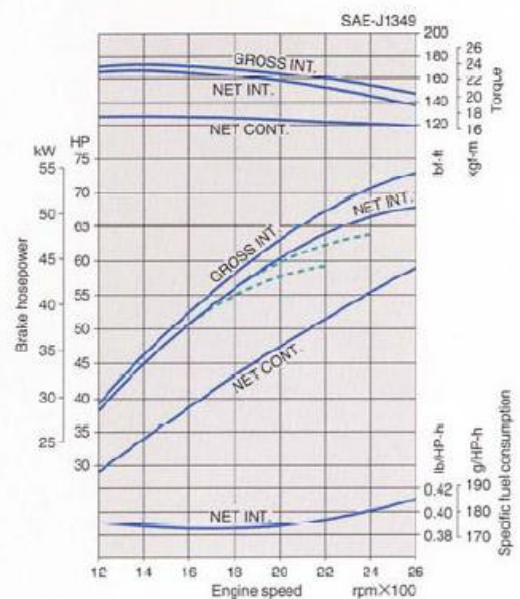

# Kubota V3300-T

## V3-Serie

Importeur Kubota  
 Motoren Nederland:  
 Prins Maasdijk  
 Tuindersweg 37  
 2676BD Maasdijk  
 Tel. 0174-516240  
 Fax 0174-518142  
 info@prinsmaasdijk.nl  
 www.prinsmaasdijk.nl



### Specificaties

Model	V3300-T (low fan)	
Emissie reglement	Stage II / Tier 2	
Type motor	Verticale watergekoelde 4-takt diesel	
Aantal cilinders	4	
Boring	mm	98
Slag	mm	110
Cilinderinhoud	L	3.318
Inspuitsysteem	IDI	
Inlaatsysteem	Turbo	
Max toerental	rpm	2600(Belast)
Uitgaand vermogen		
Netto intermitterend	kW (pk)	61.9 (83.0)
Continu vermogen	kW (pk)	53.8 (72.1)
Draairichting	Tegen de klok in (vliegwielszijde)	
Droog gewicht	kg	250

### Afmetingen

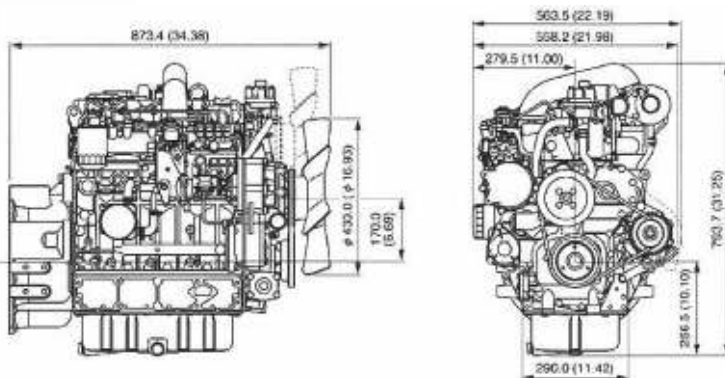





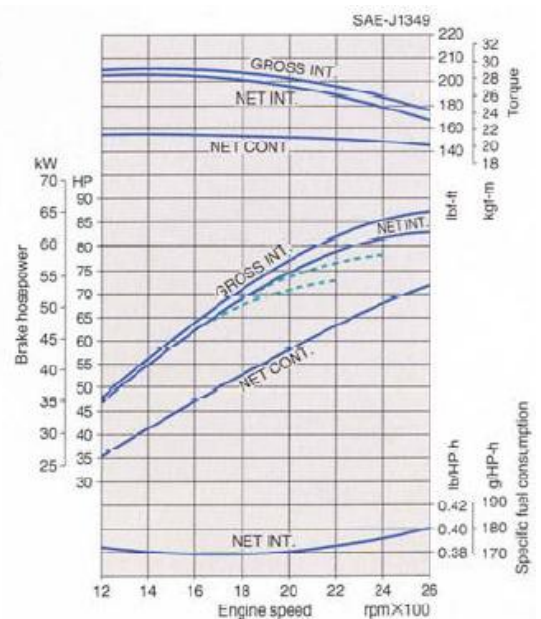

De specificaties van de motor kunnen aan wijzigingen onderhevig zijn.

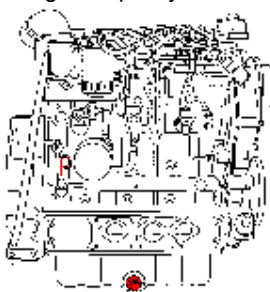

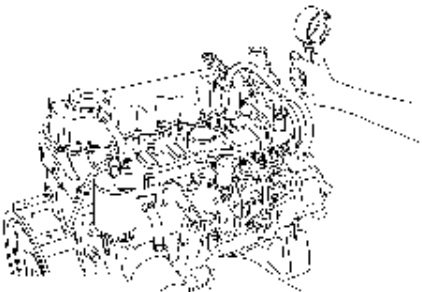
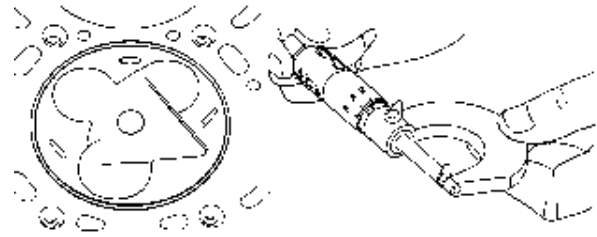
### Motorkarakteristieken



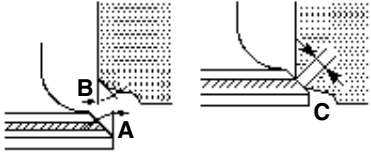

**SERVICING SPECIFICATIONS****(1) ENGINE BODY**

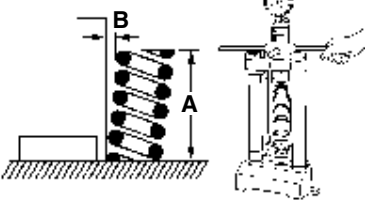
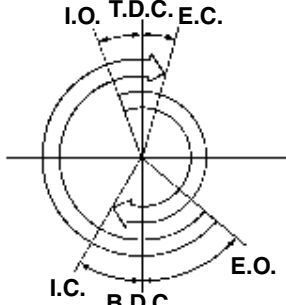

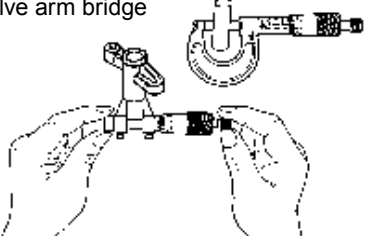
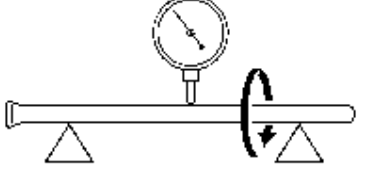

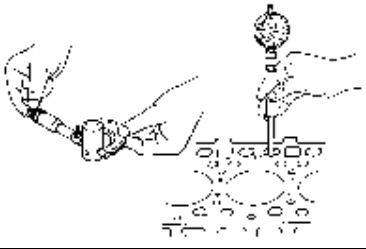
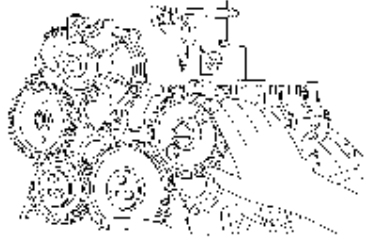
Item		Factory Specification	Allowable Limit
Lubricating oil capacity 		All models  13.2 L 3.49 U.S.gals. 2.90 Imp.gals.	—
Cylinder head surface 	Flatness	All models	—  0.05 mm / 500 mm 0.0020 in. / 19.69 in.
Compression pressure 		V3300-E2B  4.32 MPa / 250 min <sup>-1</sup> (rpm) 44 kgf/cm <sup>2</sup> / 250 min <sup>-1</sup> (rpm) 626 psi / 250 min <sup>-1</sup> (rpm)	3.26 MPa / 250 min <sup>-1</sup> (rpm) 33.2 kgf/cm <sup>2</sup> / 250 min <sup>-1</sup> (rpm) 472 psi / 250 min <sup>-1</sup> (rpm)
		V3300-T-E2B  3.92 MPa / 250 min <sup>-1</sup> (rpm) 40 kgf/cm <sup>2</sup> / 250 min <sup>-1</sup> (rpm) 569 psi / 250 min <sup>-1</sup> (rpm)	2.99 MPa / 250 min <sup>-1</sup> (rpm) 30.5 kgf/cm <sup>2</sup> / 250 min <sup>-1</sup> (rpm) 434 psi / 250 min <sup>-1</sup> (rpm)
Top clearance 		V3300-E2B  0.72 to 0.90 mm 0.0283 to 0.0354 in.	—
		V3300-T-E2B  0.92 to 1.10 mm 0.0362 to 0.0433 in.	—
Valve clearance (When cold) 		All models	—  0.23 to 0.27 mm 0.0091 to 0.0106 in.

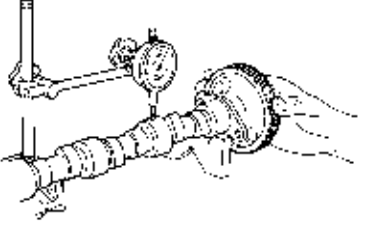

Item			Factory Specification	Allowable Limit
Valve & valve seat 	Face angle (A) (Intake)	All models	1.047 rad. 60°	—
	Face angle (A) (Exhaust)	All models	0.785 rad. 45°	—
	Seat angle (B) (Intake)	All models	1.047 rad. 60°	—
	Seat angle (B) (Exhaust)	All models	0.785 rad. 45°	—
	Seat width (C) (Intake)	All models	2.12 mm 0.0835 in.	—
	Seat width (C) (Exhaust)	All models	2.12 mm 0.0835 in.	—
Valve stem to valve guide 	Clearance (Intake)	All models	0.055 to 0.085 mm 0.0022 to 0.0033 in.	0.1 mm 0.0039 in.
	Clearance (Exhaust)	All models	0.040 to 0.070 mm 0.0016 to 0.0028 in.	0.1 mm 0.0039 in.
	Valve stem O.D. (Intake)	All models	6.960 to 6.975 mm 0.2740 to 0.2764 in.	—
	Valve stem O.D. (Exhaust)	All models	7.960 to 7.975 mm 0.3134 to 0.3140 in.	—
	Valve guide I.D. (Intake)	All models	7.030 to 7.045 mm 0.2768 to 0.2774 in.	—
	Valve guide I.D. (Exhaust)	All models	8.015 to 8.030 mm 0.3155 to 0.3161 in.	—
Valve recessing 	Intake valve	All models	0 mm (Protrusion) to 0.20 mm (Recessing) 0 in. (Protrusion) to 0.0079 in. (Recessing)	0.4 mm (Recessing) 0.0157 in. (Recessing)
	Exhaust valve	All models	0.15 mm (Protrusion) to 0.05 mm (Recessing) 0.0059 in. (Protrusion) to 0.0019 in. (Recessing)	0.4 mm (Recessing) 0.0157 in. (Recessing)

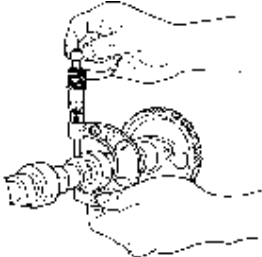
Item			Factory Specification	Allowable Limit
Valve spring 	Free length (A) (Intake)	All models	35.1 to 35.6 mm 1.3819 to 1.4016 in.	34.6 mm 1.3622 in.
	Free length (A) (Exhaust)	All models	41.7 to 42.2 mm 1.6417 to 1.6614 in.	41.2 mm 1.6220 in.
	Tilt (B) (Intake)	All models	—	1.0 mm 0.039 in.
	Tilt (B) (Exhaust)	All models	—	1.0 mm 0.039 in.
	Setting load / Setting length (Intake)	All models	63.55 N / 31.5 mm 6.48 kgf / 31.5 mm 14.26 lbs / 1.2401 in.	45.86 N / 31.5 mm 4.68 kgf / 31.5 mm 10.30 lbs / 1.2401 in.
	Setting load / Setting length (Exhaust)	All models	117.6 N / 35.0 mm 12.0 kgf / 35.0 mm 26.4 lbs / 1.3780 in.	100.0 N / 35.0 mm 10.2 kgf / 35.0 mm 22.5 lbs / 1.3780 in.
Valve timing 	Open (Intake valve)	All models	0.24 rad. before T.D.C. 14° before T.D.C.	—
	Close (Intake valve)	All models	0.61 rad. after B.D.C. 36° after B.D.C.	—
	Open (Exhaust valve)	All models	0.79 rad. before B.D.C. 45° before B.D.C.	—
	Close (Exhaust valve)	All models	0.29 rad. after T.D.C. 17° after T.D.C.	—
Rocker arm shaft to rocker arm 	Clearance	All models	0.016 to 0.045 mm 0.0006 to 0.0018 in.	0.15 mm 0.0059 in.
	Rocker arm shaft O.D.	All models	15.973 to 15.984 mm 0.6289 to 0.6293 in.	—
	Rocker arm I.D.	All models	16.000 to 16.018 mm 0.6299 to 0.6306 in.	—
Valve arm bridge shaft to valve arm bridge 	Clearance	All models	0.018 to 0.042 mm 0.0007 to 0.0017 in.	0.15 mm 0.0059 in.
	Valve arm bridge shaft O.D.	All models	9.023 to 9.032 mm 0.3552 to 0.3556 in.	—
	Valve arm bridge I.D.	All models	9.050 to 9.065 mm 0.3563 to 0.3569 in.	—
Push rod 	Alignment	All models	—	0.25 mm 0.0098 in.



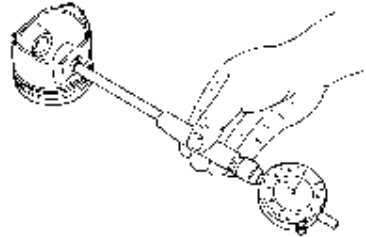
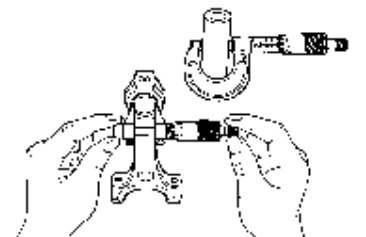

Item		Factory Specification	Allowable Limit
 <p>Tappet to tappet guide</p>	Clearance	All models 0.020 to 0.062 mm 0.0008 to 0.0024 in.	0.07 mm 0.0028 in.
	Tappet O.D.	All models 23.959 to 23.980 mm 0.9433 to 0.9441 in.	—
	Tappet guide I.D.	All models 24.000 to 24.021 mm 0.9449 to 0.9457 in.	—
 <p>Timing gear</p>	Backlash (Crank gear to idle gear 1)	All models 0.049 to 0.193 mm 0.0019 to 0.0076 in.	0.22 mm 0.0087 in.
	Backlash (Idle gear 1 to cam gear)	All models 0.049 to 0.189 mm 0.0019 to 0.0074 in.	0.22 mm 0.0087 in.
	Backlash (Idle gear 1 to idle gear 2)	All models 0.044 to 0.185 mm 0.0017 to 0.0073 in.	0.22 mm 0.0087 in.
	Backlash (Idle gear 2 to injection pump gear)	All models 0.044 to 0.177 mm 0.0017 to 0.0070 in.	0.22 mm 0.0087 in.
	Backlash (Cam gear to balancer gear 1)	Balancer model only 0.047 to 0.182 mm 0.0018 to 0.0072 in.	0.22 mm 0.0087 in.
	Backlash (Idle gear 1 to balancer gear 2)	Balancer model only 0.044 to 0.183 mm 0.0017 to 0.0072 in.	0.22 mm 0.0087 in.
 <p>Idle gear</p>	Side clearance	All models 0.15 to 0.30 mm 0.0059 to 0.0118 in.	0.9 mm 0.0354 in.
 <p>Idle gear shaft to idle gear bushing</p>	Clearance	All models 0.050 to 0.091 mm 0.0020 to 0.0036 in.	0.1 mm 0.0039 in.
	Idle gear shaft 1 O.D.	All models 44.959 to 44.975 mm 1.7700 to 1.7707 in.	—
	Idle gear shaft 2 O.D.	All models 44.959 to 44.975 mm 1.7700 to 1.7707 in.	—
	Idle gear bushing I.D.	All models 45.025 to 45.050 mm 1.7726 to 1.7736 in.	—
 <p>Camshaft</p>	Alignment	All models —	0.01 mm 0.0004 in.

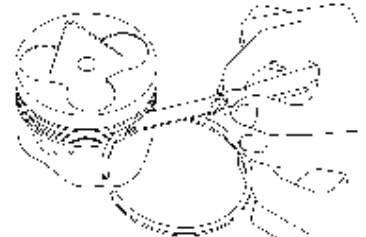

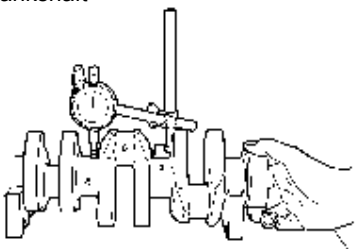

Item			Factory Specification	Allowable Limit
Camshaft 	Side clearance	All models	0.07 to 0.22 mm 0.0028 to 0.0087 in.	0.3 mm 0.0118 in.
Cam 	Height (Intake)	All models	37.63 mm 1.4815 in.	37.13 mm 1.4618 in.
	Height (Exhaust)	All models	38.96 mm 1.5338 in.	38.46 mm 1.5141 in.
Camshaft journal to camshaft bearing 	Oil clearance	All models	0.050 to 0.091 mm 0.0020 to 0.0036 in.	0.15 mm 0.0059 in.
	Camshaft journal O.D.	All models	45.934 to 45.950 mm 1.8084 to 1.8091 in.	—
	Camshaft bearing I.D.	All models	46.000 to 46.025 mm 1.8110 to 1.8120 in.	—
Balancer shaft 	Side clearance	Balancer model only	0.07 to 0.22 mm 0.0028 to 0.0087 in.	0.3 mm 0.0118 in.
Balancer shaft 	Alignment	Balancer model only	—	0.02 mm 0.0008 in.

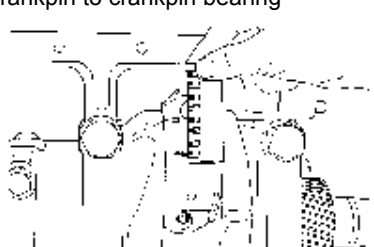
Item			Factory Specification	Allowable Limit
Balancer shaft journal to balancer shaft bearing 	Oil clearance	Balancer model only	0.070 to 0.159 mm 0.0028 to 0.0063 in.	0.2 mm 0.0079 in.
	Balancer shaft journal O.D.	Balancer model only	50.921 to 50.940 mm 2.0048 to 2.0055 in.	—
	Balancer shaft bearing I.D. (A and B)	Balancer model only	51.010 to 51.080 mm 2.0083 to 2.0110 in.	—
Piston pin bore 	Piston pin bore I.D.	All models	30.000 to 30.013 mm 1.1811 to 1.1816 in.	30.05 mm 1.1831 in.
Piston pin to small end bushing 	Clearance	All models	0.020 to 0.040 mm 0.0008 to 0.0016 in.	0.15 mm 0.0059 in.
	Piston pin O.D.	All models	30.006 to 30.011 mm 1.1813 to 1.1815 in.	—
	Small end bushing I.D.	All models	30.031 to 30.046 mm 1.1823 to 1.1829 in.	—
Piston ring 	Ring gap (Top ring)	All models	0.30 to 0.45 mm 0.0118 to 0.0177 in.	1.25 mm 0.0492 in.
	Ring gap (Second ring)	All models	0.30 to 0.45 mm 0.0118 to 0.0177 in.	1.25 mm 0.0492 in.
	Ring gap (Oil ring)	All models	0.25 to 0.45 mm 0.0098 to 0.0177 in.	1.25 mm 0.0492 in.
Piston ring groove to piston ring 	Clearance (Second ring)	All models	0.093 to 0.120 mm 0.0037 to 0.0047 in.	0.2 mm 0.0079 in.
	Clearance (Oil ring)	All models	0.020 to 0.060 mm 0.0008 to 0.0024 in.	0.15 mm 0.0059 in.

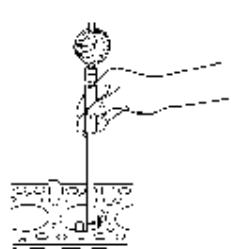

Item			Factory Specification	Allowable Limit
Connecting rod 	Alignment	All models	—	0.05 mm 0.0020 in.
Crankshaft 	Alignment	All models	—	0.02 mm 0.0008 in.
Crankshaft journal to crankshaft bearing 	Oil clearance	All models	0.018 to 0.062 mm 0.0007 to 0.0024 in.	0.2 mm 0.0079 in.
	Crankshaft journal O.D.	All models	74.977 to 74.990 mm 2.9518 to 2.9524 in.	—
Crankpin to crankpin bearing 	Oil clearance	All models	0.018 to 0.051 mm 0.0007 to 0.0020 in.	0.2 mm 0.0079 in.
	Crankpin O.D.	All models	52.977 to 52.990 mm 2.0857 to 2.0862 in.	—
Crankshaft 	Side clearance	All models	0.15 to 0.31 mm 0.0059 to 0.0122 in.	0.5 mm 0.0197 in.
Cylinder 	Bore I.D. (Standard size)	All models	98.000 to 98.022 mm 3.8583 to 3.8591 in.	98.15 mm 3.8642 in.
	Bore I.D. (Oversize)	All models	98.500 to 98.522 mm 3.8780 to 3.8788 in.	98.65 mm 3.8839 in.

**(2) LUBRICATING SYSTEM**

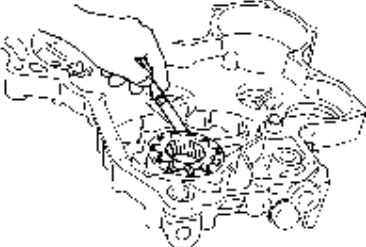
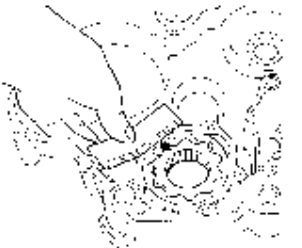
Item		Factory Specification	Allowable Limit
Engine oil pressure 	Engine oil pressure (At idle speed)	All models —	49.0 kPa 0.5 kgf/cm <sup>2</sup> 7.1 psi
	Engine oil pressure (At rated speed)	All models 196.1 to 392.3 kPa 2.0 to 4.0 kgf/cm <sup>2</sup> 28.4 to 56.9 psi	147.1 kPa 1.5 kgf/cm <sup>2</sup> 21.3 psi
Inner rotor to outer rotor (Oil pump) 	Clearance	All models 0.040 to 0.160 mm 0.0016 to 0.0063 in.	0.30 mm 0.0118 in.
Outer rotor to pump body (Oil pump) 	Clearance	All models 0.100 to 0.184 mm 0.0039 to 0.0072 in.	0.30 mm 0.0118 in.
Inner rotor to cover (Oil pump) 	Clearance	All models 0.025 to 0.075 mm 0.0010 to 0.0030 in.	0.225 mm 0.0089 in.

**(3) COOLING SYSTEM**

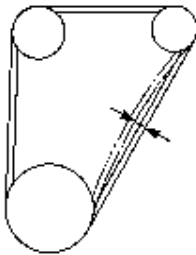
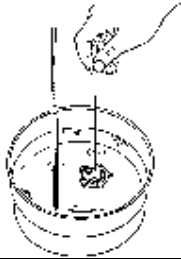
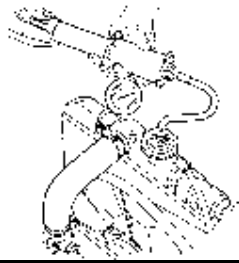
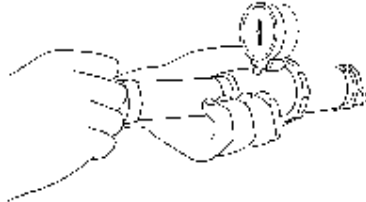
Item			Factory Specification	Allowable Limit
Fan belt 	Tension	All models	10 to 12 mm (0.394 to 0.472 in.) deflection at 98 N (10 kgf, 22 lbs) of force	—
Thermostat 	Valve opening temperature (At beginning)	All models	74.5 to 78.5 °C 166.1 to 173.3 °F	—
	Valve opening temperature (Opened completely)	All models	90 °C 194 °F	—
Radiator 	Water tightness	All models	No water leak at 137 kPa 1.4 kgf/cm <sup>2</sup> 20 psi	—
Radiator cap 	Pressure falling time	All models	10 seconds or more for pressure falling from 88 to 59 kPa (from 0.9 to 0.6 kgf/cm <sup>2</sup> , from 13 to 9 psi)	—

**(4) FUEL SYSTEM**

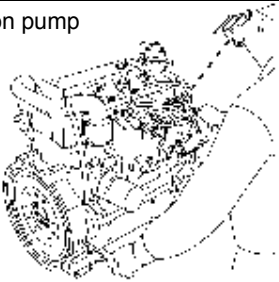
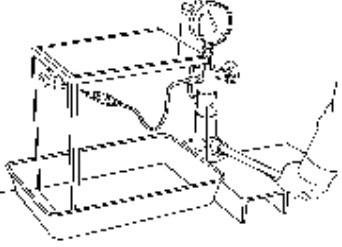
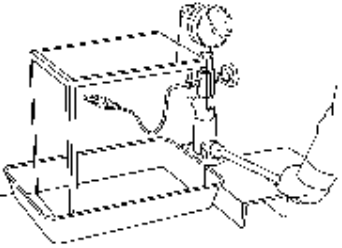
Item		Factory Specification	Allowable Limit	
Injection pump 	Injection timing	V3300-E2B	0.20 to 0.22 rad. before T.D.C. 11.5 to 12.5° before T.D.C.	—
		V3300-T-E2B	0.11 to 0.13 rad. before T.D.C. 6.5 to 7.5° before T.D.C.	—
Injection nozzle 	Injection pressure	All models	13.73 to 14.71 MPa 140 to 150 kgf/cm <sup>2</sup> 1991 to 2133 psi	—
Injection nozzle 	Valve seat tightness	All models	No fuel leak at 12.75 MPa 130 kgf/cm <sup>2</sup> 1849 psi	—

**(5) ELECTRICAL SYSTEM**

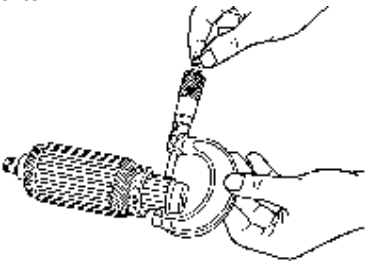
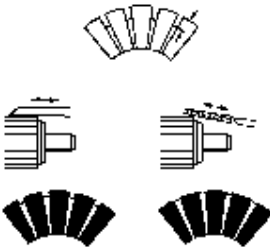
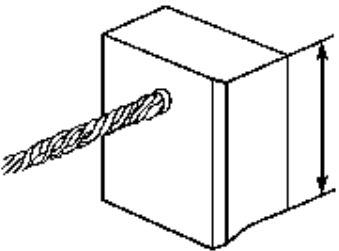
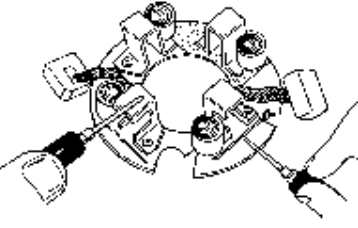
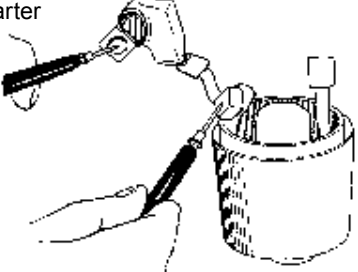
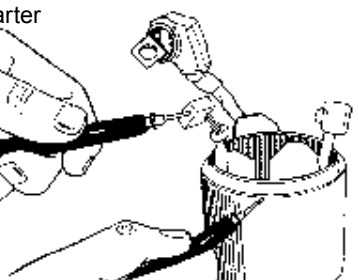
Item			Factory Specification	Allowable Limit
Starter 	Commutator O.D.	All models	32.0 mm 1.2598 in.	31.4 mm 1.2362 in.
Starter 	Mica under cut	All models	0.50 mm 0.0197 in.	0.20 mm 0.0079 in.
Starter 	Brush length	All models	18.0 mm 0.7087 in.	11.0 mm 0.4331 in.
Starter 	Brush holder resistance (Brush holder - Holder support)	All models	Infinity	—
Starter 	Field coil resistance (Lead - Brush)	All models	Continuity	—
Starter 	Field coil resistance (Brush - Yoke)	All models	Infinity	—

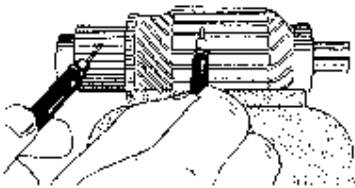
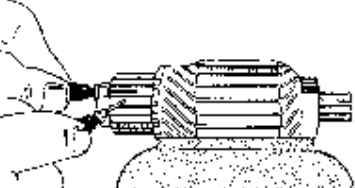
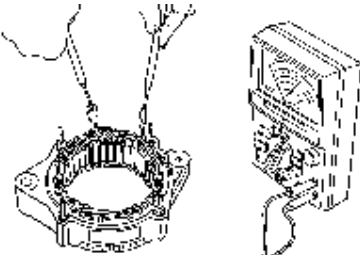
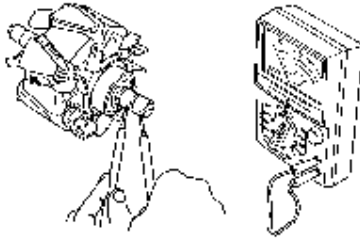
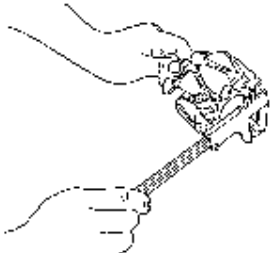
Item			Factory Specification	Allowable Limit
Starter 	Armature coil resistance (Commutator - Armature coil core)	All models	Infinity	—
Starter 	Armature coil resistance (Segment - Segment)	All models	Continuity	—
Alternator 	Stator resistance	All models	Less than 1.0 $\Omega$	—
Alternator 	Rotor resistance	All models	2.8 to 3.3 $\Omega$	—
Alternator 	Slip ring O.D.	All models	22.7 mm 0.8937 in.	22.1 mm 0.8701 in.

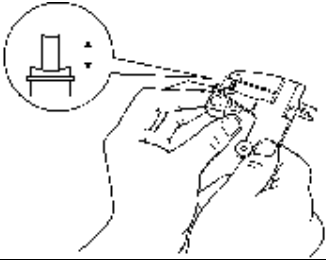
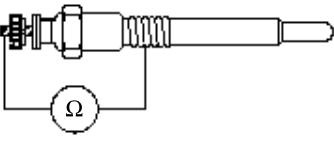

Item	Factory Specification		Allowable Limit
<p>Alternator</p> 	Brush length	All models	18.5 mm 0.7283 in.  5.0 mm 0.1969 in.
<p>Glow plug</p> 	Resistance	All models	Approx. 1.0 Ω  —

## TIGHTENING TORQUES

### (1) Special Tightening Torques

For "\*" marked screws, bolts and nuts on under table, apply engine oil to their threads and seats before tightening.

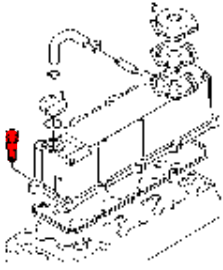
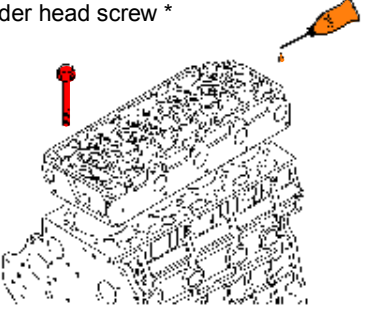
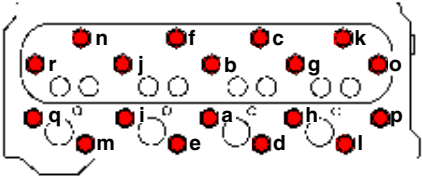
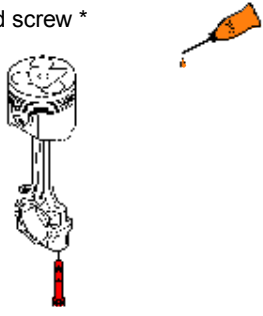
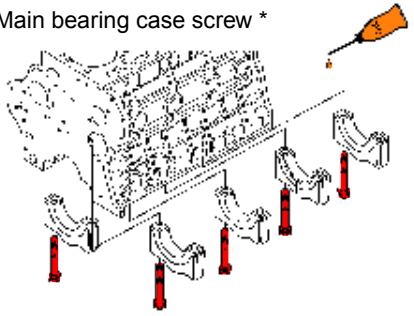
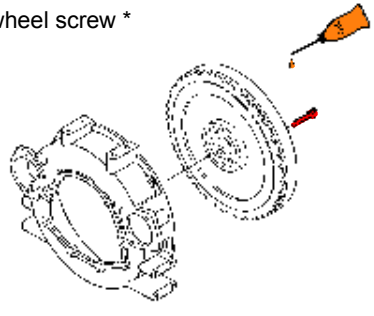
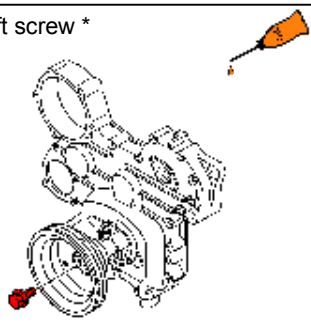
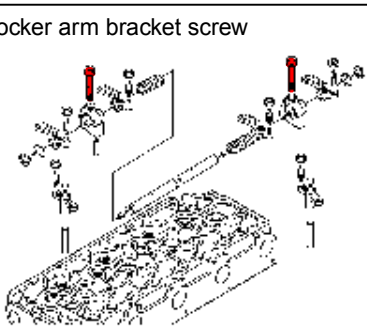
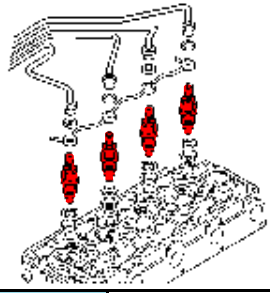
Cylinder head cover screw 		Cylinder head screw * 		Cylinder head tightening order 	
V3300-E2B	6.9 to 11.3 N·m 0.70 to 1.15 kgf·m	V3300-E2B	98.1 to 107.9 N·m 10.0 to 11.0 kgf·m	V3300-E2B	a → r
V3300-T-E2B	5.1 to 8.3 ft-lbs	V3300-T-E2B	72.3 to 79.6 ft-lbs	V3300-T-E2B	
Connecting rod screw * 		Main bearing case screw * 		Flywheel screw * 	
V3300-E2B	78.5 to 83.4 N·m 8.0 to 8.5 kgf·m	V3300-E2B	137.3 to 147.1 N·m 14.0 to 15.0 kgf·m	V3300-E2B	98.1 to 107.9 N·m 10.0 to 11.0 kgf·m
V3300-T-E2B	57.9 to 61.5 ft-lbs	V3300-T-E2B	101.3 to 108.5 ft-lbs	V3300-T-E2B	72.3 to 79.6 ft-lbs
Crankshaft screw * 		Rocker arm bracket screw 		Nozzle holder assembly 	
V3300-E2B	255.1 to 274.7 N·m 26.0 to 28.0 kgf·m	V3300-E2B	49.0 to 55.9 N·m 5.0 to 5.7 kgf·m	V3300-E2B	49.0 to 68.6 N·m 5.0 to 7.0 kgf·m
V3300-T-E2B	188.1 to 202.5 ft-lbs	V3300-T-E2B	36.2 to 41.2 ft-lbs	V3300-T-E2B	36.2 to 50.6 ft-lbs

Injection pipe retaining nut

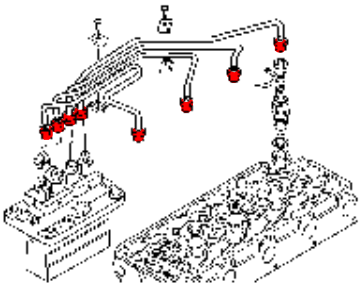

V3300-E2B	22.6 to 36.3 N·m 2.3 to 3.7 kgf·m
V3300-T-E2B	16.6 to 26.8 ft-lbs

Overflow pipe assembly retaining nut

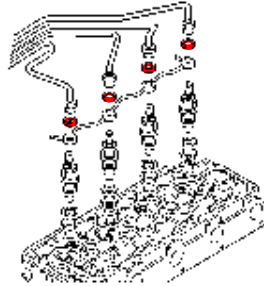

V3300-E2B	19.6 to 24.5 N·m 2.0 to 2.5 kgf·m
V3300-T-E2B	14.5 to 18.1 ft-lbs

Glow plug

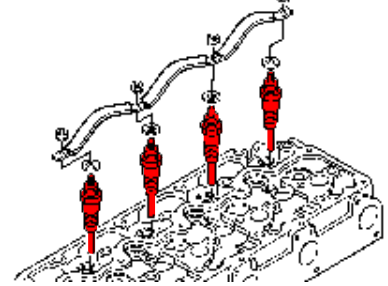

V3300-E2B	19.6 to 24.5 N·m 2.0 to 2.5 kgf·m
V3300-T-E2B	14.5 to 18.1 ft-lbs

Oil cooler joint screw

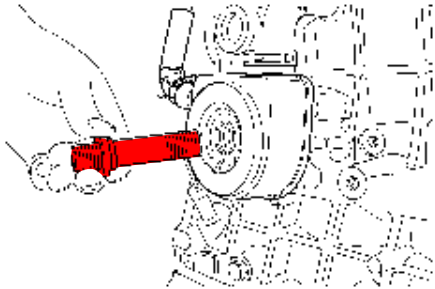

V3300-E2B	39.2 to 44.1 N·m 4.0 to 4.5 kgf·m
V3300-T-E2B	28.9 to 32.5 ft-lbs

Oil switch taper screw



V3300-E2B	14.7 to 19.6 N·m 1.5 to 2.0 kgf·m
V3300-T-E2B	10.8 to 14.5 ft-lbs

Oil pump cover screw

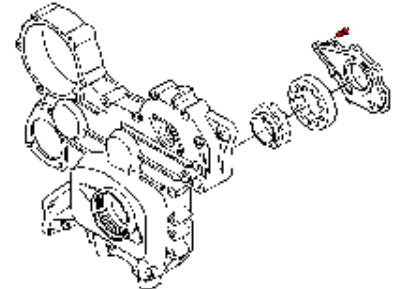

V3300-E2B	7.9 to 9.3 N·m 0.80 to 0.95 kgf·m
V3300-T-E2B	5.8 to 6.9 ft-lbs

Injection pump gear mounting nut



V3300-E2B	73.6 to 83.4 N·m 7.5 to 8.5 kgf·m
V3300-T-E2B	54.2 to 61.5 ft-lbs

Injection pump unit mounting nut

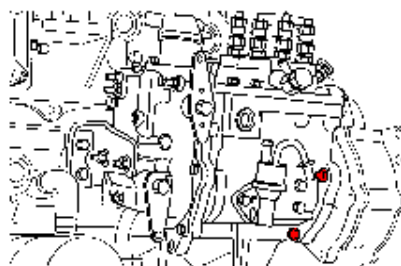

V3300-E2B	17.7 to 20.6 N·m 1.8 to 2.1 kgf·m
V3300-T-E2B	13.0 to 15.2 ft-lbs

Gear case cover mounting screw

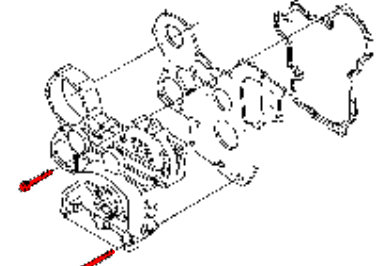

V3300-E2B	23.5 to 27.5 N·m 2.4 to 2.8 kgf·m
V3300-T-E2B	17.4 to 20.3 ft-lbs

Relief valve retaining screw

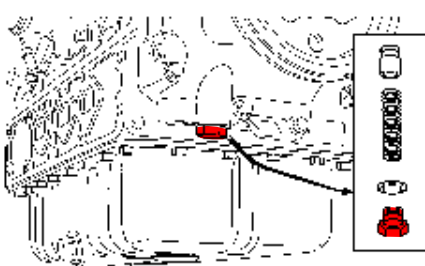

V3300-E2B	68.6 to 78.4 N·m 7.0 to 8.0 kgf·m
V3300-T-E2B	50.6 to 57.9 ft-lbs

Idle gear mounting screw

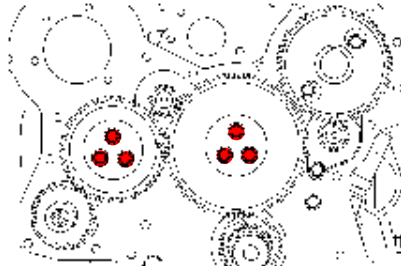

V3300-E2B	23.5 to 27.5 N·m 2.4 to 2.8 kgf·m
V3300-T-E2B	17.4 to 20.3 ft-lbs

Plate mounting screw



V3300-E2B	23.5 to 27.5 N·m 2.4 to 2.8 kgf·m
V3300-T-E2B	17.4 to 20.3 ft-lbs

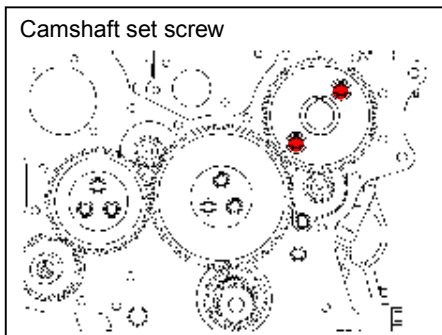

Camshaft set screw

V3300-E2B	23.5 to 27.5 N·m 2.4 to 2.8 kgf·m
V3300-T-E2B	17.4 to 20.3 ft-lbs

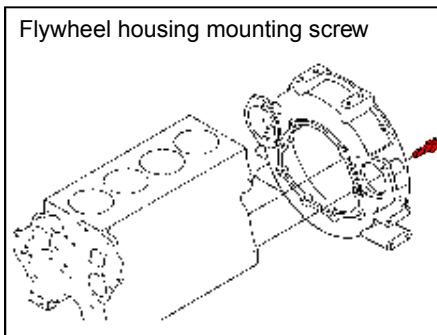

Flywheel housing mounting screw

V3300-E2B	77.5 to 90.2 N·m 7.9 to 9.2 kgf·m
V3300-T-E2B	57.1 to 66.5 ft-lbs

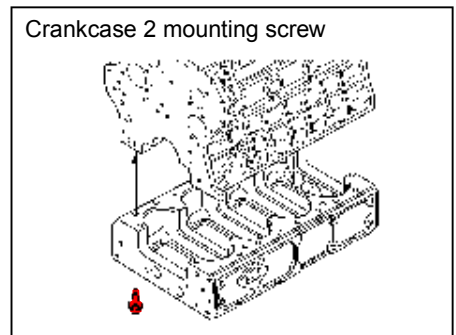

Crankcase 2 mounting screw

V3300-E2B	49.0 to 55.9 N·m 5.0 to 5.7 kgf·m
V3300-T-E2B	36.2 to 41.2 ft-lbs

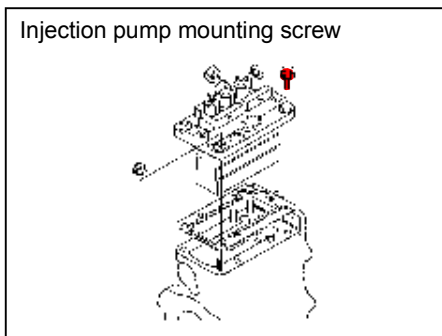

Injection pump mounting screw

V3300-E2B	23.5 to 27.5 N·m 2.4 to 2.8 kgf·m
V3300-T-E2B	17.4 to 20.3 ft-lbs

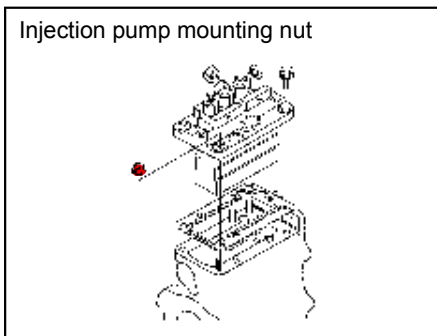

Injection pump mounting nut

V3300-E2B	17.7 to 20.6 N·m 1.8 to 2.1 kgf·m
V3300-T-E2B	13.0 to 15.2 ft-lbs

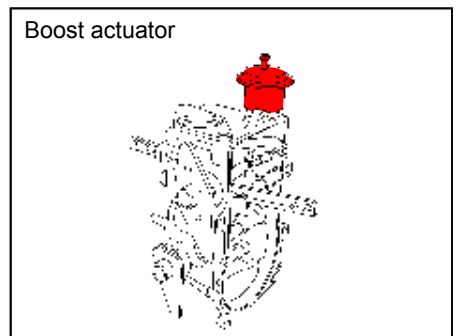

Boost actuator

V3300-E2B	39.2 to 45.1 N·m 4.0 to 4.6 kgf·m
V3300-T-E2B	28.9 to 33.3 ft-lbs

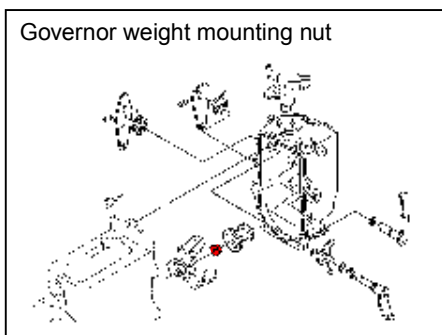

Governor weight mounting nut

V3300-E2B	62.8 to 72.6 N·m 6.4 to 7.4 kgf·m
V3300-T-E2B	46.3 to 53.5 ft-lbs

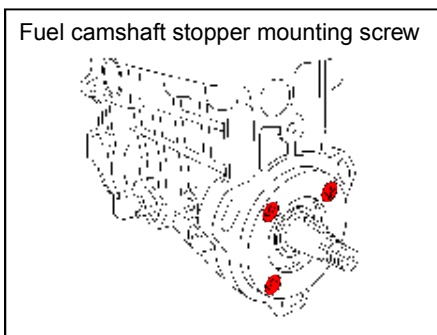

Fuel camshaft stopper mounting screw

V3300-E2B	7.9 to 9.3 N·m 0.80 to 0.95 kgf·m
V3300-T-E2B	5.8 to 6.9 ft-lbs

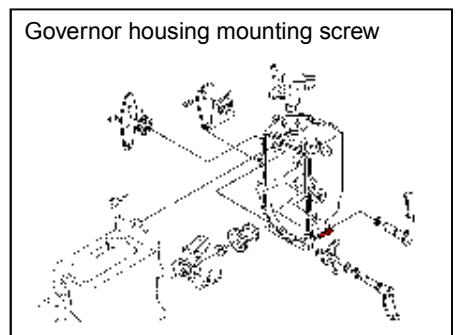

Governor housing mounting screw

V3300-E2B	9.8 to 11.3 N·m 1.00 to 1.15 kgf·m
V3300-T-E2B	7.23 to 8.32 ft-lbs

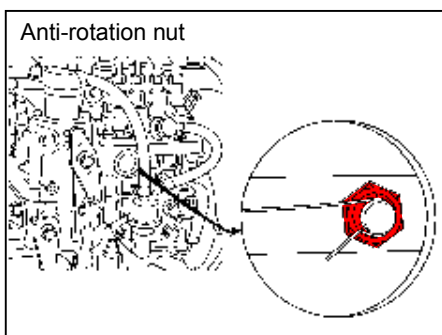

Anti-rotation nut

V3300-E2B	2.84 to 4.02 N·m 0.29 to 0.41 kgf·m
V3300-T-E2B	2.10 to 2.97 ft-lbs

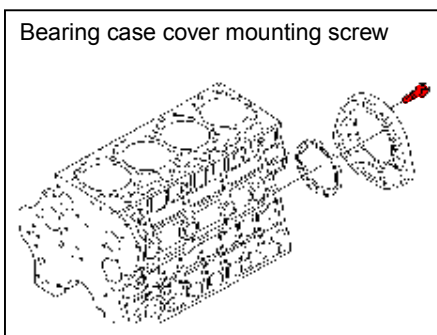

Bearing case cover mounting screw

V3300-E2B	23.5 to 27.5 N·m 2.4 to 2.8 kgf·m
V3300-T-E2B	17.4 to 20.3 ft-lbs

**(2) General Tightening Torques**

Screw and bolt material grades are shown by numbers punched on the screw and bolt heads.

Prior to tightening, be sure to check out the numbers as shown below.

None or 4□ : Standard grade

7□ : Special grade

Nominal Diameter	Standard Grade	Special Grade
M6	7.9 to 9.3 N·m 0.80 to 0.95 kgf·m 5.8 to 6.9 ft-lbs	9.8 to 11.3 N·m 1.00 to 1.15 kgf·m 7.23 to 8.32 ft-lbs
M8	17.7 to 20.6 N·m 1.8 to 2.1 kgf·m 13.0 to 15.2 ft-lbs	23.5 to 27.5 N·m 2.4 to 2.8 kgf·m 17.4 to 20.3 ft-lbs
M10	39.2 to 45.1 N·m 4.0 to 4.6 kgf·m 28.9 to 33.3 ft-lbs	48.1 to 55.9 N·m 4.9 to 5.7 kgf·m 35.4 to 41.2 ft-lbs
M12	62.8 to 72.6 N·m 6.4 to 7.4 kgf·m 46.3 to 53.5 ft-lbs	77.5 to 90.2 N·m 7.9 to 9.2 kgf·m 57.1 to 66.5 ft-lbs