

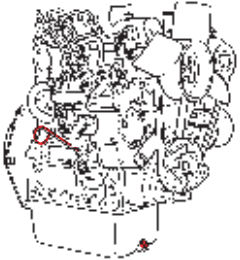

SERVICING SPECIFICATIONS

(1) ENGINE BODY

Item		Factory Specification		Allowable Limit
Lubricating oil capacity 	Oil pan depth 121 mm (4.76 in.)	Z482-E4B	2.5 L 0.66 U.S.gals	—
		D722-E4B	3.8 L 1.0 U.S.gals	—
		D782-E4B	3.6 L 0.95 U.S.gals	—
	Oil pan depth 101 mm (3.98 in.)	Z482-E4B	2.1 L 0.55 U.S.gals	—
		Z602-E4B	2.5 L 0.66 U.S.gals	—
		D722-E4B	3.2 L 0.85 U.S.gals	—
		D902-E4B	3.7 L 0.98 U.S.gals	—
	Cylinder head surface 	Flatness	All models	—
Compression pressure 	Z482-E4B D722-E4B D782-E4B	2.85 to 3.23 MPa 29.0 to 33.0 kgf/cm ² 413 to 469 psi	2.26 MPa 23.0 kgf/cm ² 327 psi	
	Z602-E4B D902-E4B	3.53 to 4.02 MPa 36.0 to 41.0 kgf/cm ² 512 to 583 psi	2.55 MPa 26.0 kgf/cm ² 370 psi	
Top clearance 	All models	0.50 to 0.70 mm 0.020 to 0.027 in.	—	

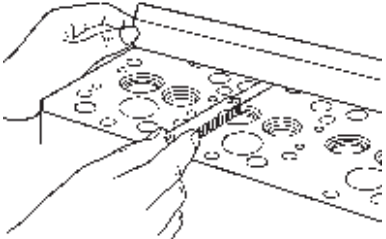

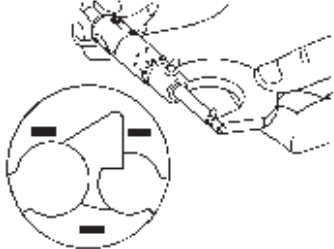
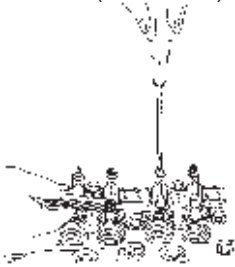
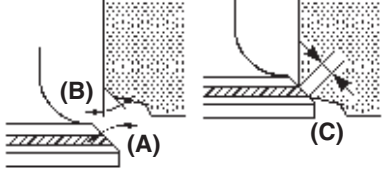
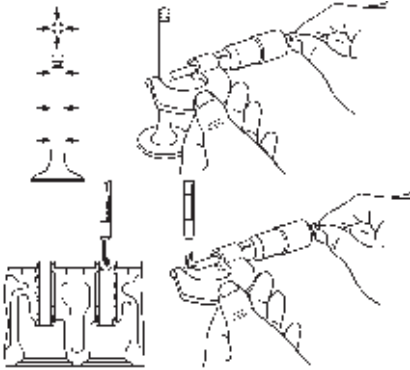
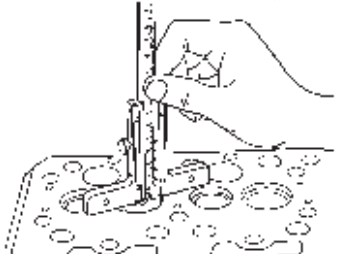
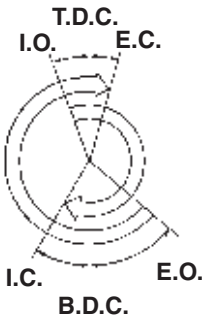
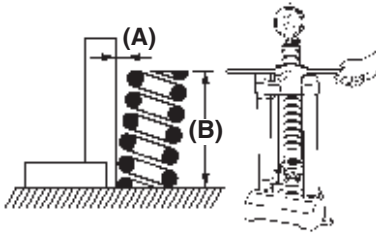
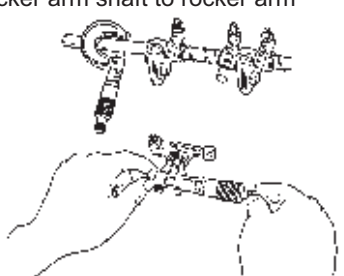
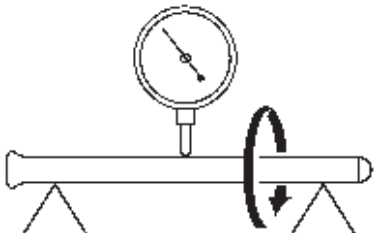
Item		Factory Specification	Allowable Limit	
Valve clearance (When cold) 	All models	0.145 to 0.185 mm 0.00571 to 0.00728 in.	—	
Valve & valve seat 	Face angle (A)	All models	0.79 rad 45°	—
	Seat angle (B)	All models	0.79 rad 45°	—
	Seat width (C)	All models	2.12 mm 0.0835 in.	—
Valve stem to valve guide 	Clearance	All models	0.030 to 0.057 mm 0.0012 to 0.0022 in.	0.10 mm 0.0039 in.
	Valve stem O.D.	All models	5.968 to 5.980 mm 0.2350 to 0.2354 in.	—
	Valve guide I.D.	All models	6.010 to 6.025 mm 0.2367 to 0.2372 in.	—
Valve protrusion or recessing 	All models	-0.10 mm (Protrusion) to 0.10 mm (Recessing) -0.0039 in. (Protrusion) to 0.0039 in. (Recessing)	0.30 mm (Recessing) 0.012 in. (Recessing)	

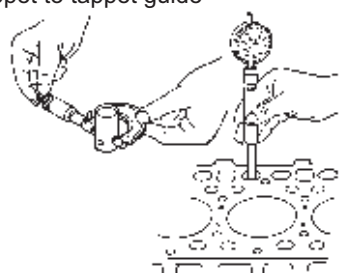
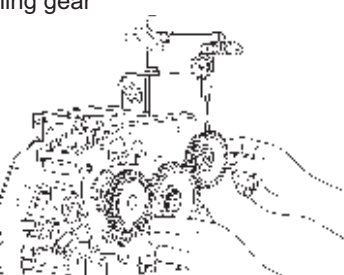
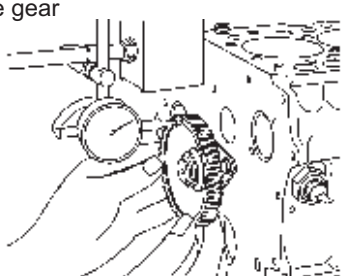
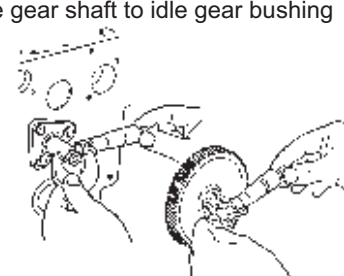
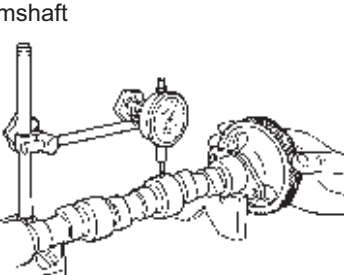
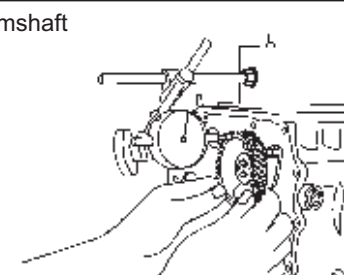
Item		Factory Specification	Allowable Limit	
Valve timing 	Open (Intake Valve)	Z482-E4B D722-E4B D782-E4B	0.445 rad before T.D.C 25.5° before T.D.C	—
	Close (Intake Valve)		0.881 rad after B.D.C. 50.5° after B.D.C	—
	Open (Exhaust Valve)		0.969 rad before B.D.C 55.5° before B.D.C	—
	Close (Exhaust Valve)		0.201 rad after T.D.C 11.5° after T.D.C	—
	Open (Intake Valve)	Z602-E4B D902-E4B	0.35 rad before T.D.C 20° before T.D.C	—
	Close (Intake Valve)		0.79 rad after B.D.C. 45° after B.D.C	—
	Open (Exhaust Valve)		0.87 rad before B.D.C 50° before B.D.C	—
	Close (Exhaust Valve)		0.26 rad after T.D.C 15° after T.D.C	—
Valve spring 	Tilt (A)	All models	—	1.2 mm 0.047 in.
	Free length (B)	All models	31.3 to 31.8 mm 1.24 to 1.25 in.	28.4 mm 1.12 in.
	Setting load / Setting length	All models	65 N / 27.0 mm 6.6 kgf / 27.0 mm 15 lbf / 1.06 in.	55 N / 27.0 mm 5.6 kgf / 27.0 mm 12 lbf / 1.06 in.
Rocker arm shaft to rocker arm 	Oil clearance	All models	0.016 to 0.045 mm 0.00063 to 0.0017 in.	0.15 mm 0.0059 in.
	Rocker arm shaft O.D.	All models	10.473 to 10.484 mm 0.41233 to 0.41275 in.	—
	Rocker arm I.D.	All models	10.500 to 10.518 mm 0.41339 to 0.41409 in.	—
Push rod 	Alignment	All models	—	0.25 mm 0.0098 in.

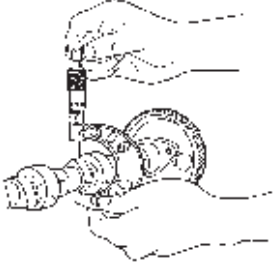
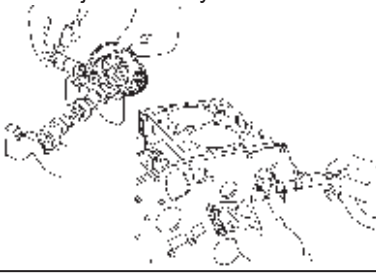
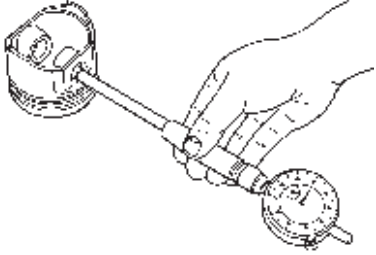
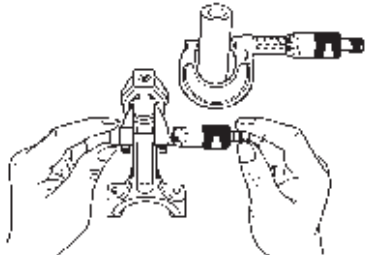
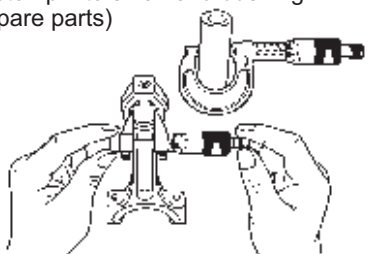
Item		Factory Specification	Allowable Limit
 <p>Tappet to tappet guide</p>	Clearance	All models 0.016 to 0.052 mm 0.00063 to 0.0020 in.	0.10 mm 0.0039 in.
	Tappet O.D.	All models 17.966 to 17.984 mm 0.70733 to 0.70803 in.	—
	Tappet guide I.D.	All models 18.000 to 18.018 mm 0.70867 to 0.70937 in.	—
 <p>Timing gear</p>	Backlash (Crank gear to idle gear)	All models 0.0430 to 0.124 mm 0.00170 to 0.00488 in.	0.15 mm 0.0059 in.
	Backlash (Idle gear to cam gear)	All models 0.0470 to 0.123 mm 0.00185 to 0.00484 in.	0.15 mm 0.0059 in.
	Backlash (Idle gear to injection pump gear)	All models 0.0460 to 0.124 mm 0.00182 to 0.00488 in.	0.15 mm 0.0059 in.
	Backlash (Crank gear to oil pump drive gear)	All models 0.0410 to 0.123mm 0.00162 to 0.00484 in.	0.15 mm 0.0059 in.
 <p>Idle gear</p>	Side clearance	All models 0.20 to 0.51 mm 0.0079 to 0.020 in.	0.80 mm 0.031 in.
 <p>Idle gear shaft to idle gear bushing</p>	Oil clearance	All models 0.020 to 0.084 mm 0.00079 to 0.0033 in.	0.10 mm 0.0039 in.
	Idle gear shaft O.D.	All models 19.967 to 19.980 mm 0.78611 to 0.78661 in.	—
	Idle gear bushing I.D.	All models 20.000 to 20.051 mm 0.78741 to 0.78940 in.	—
 <p>Camshaft</p>	Alignment	All models —	0.01 mm 0.0004 in.
 <p>Camshaft</p>	Side clearance	All models 0.15 to 0.31 mm 0.0059 to 0.012 in.	0.50 mm 0.020 in.

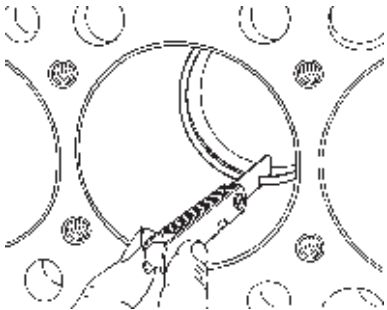
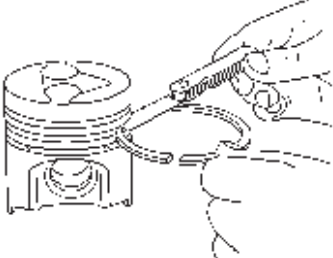
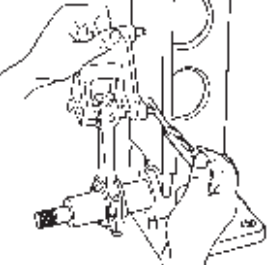
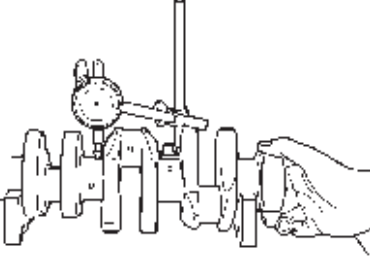
Item		Factory Specification	Allowable Limit	
Cam 	Height (Intake)	Z482-E4B D722-E4B D782-E4B	26.88 mm 1.058 in.	26.83 mm 1.056 in.
	Height (Exhaust)		25.88 mm 1.019 in.	25.83 mm 1.017 in.
	Height (Intake)	Z602-E4B D902-E4B	26.88 mm 1.058 in.	26.83 mm 1.056 in.
	Height (Exhaust)		26.88 mm 1.058 in.	26.83 mm 1.056 in.
Camshaft journal to cylinder block bore 	Oil clearance	All models	0.050 to 0.091 mm 0.0020 to 0.0035 in.	0.15 mm 0.0059 in.
	Camshaft journal O.D.	All models	32.934 to 32.950 mm 1.2967 to 1.2972 in.	—
	Cylinder block bore I.D.	All models	33.000 to 33.025 mm 1.2993 to 1.3001 in.	—
Piston pin bore 	Piston pin bore I.D.	All models	20.000 to 20.013 mm 0.78741 to 0.78791 in.	20.05 mm 0.7894 in.
Piston pin to small end bushing 	Oil clearance	All models	0.014 to 0.038 mm 0.00056 to 0.0014 in.	0.10 mm 0.0039 in.
	Piston pin O.D.	All models	20.002 to 20.011 mm 0.78748 to 0.78783 in.	—
	Small end bushing I.D.	All models	20.025 to 20.040 mm 0.78839 to 0.78897 in.	—
Piston pin to small end bushing (Spare parts) 	Oil clearance	All models	0.015 to 0.075 mm 0.00059 to 0.0029 in.	0.15 mm 0.0059 in.
	Small end bushing I.D.	All models	20.026 to 20.077 mm 0.78843 to 0.79043 in.	—

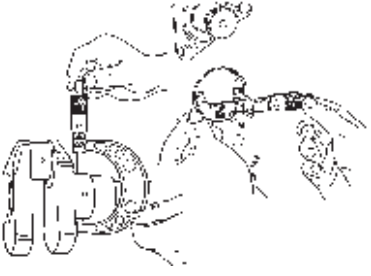
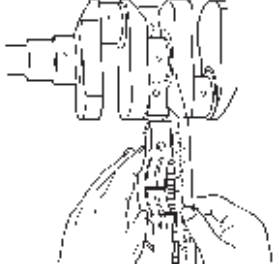
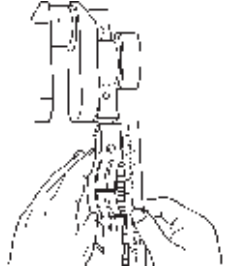
Item			Factory Specification	Allowable Limit
Piston ring 	Ring gap (Top ring)	Z482-E4B D722-E4B D782-E4B	0.12 to 0.27 mm 0.0047 to 0.010 in.	1.15 mm 0.0472 in.
		Z602-E4B D902-E4B	0.15 to 0.30 mm 0.0059 to 0.011 in.	1.20 mm 0.0472 in.
	Ring gap (Second ring)	Z482-E4B D722-E4B D782-E4B	0.30 to 0.45 mm 0.012 to 0.017 in.	1.20 mm 0.0472 in.
		Z602-E4B D902-E4B	0.35 to 0.50 mm 0.014 to 0.019 in.	1.25 mm 0.0492 in.
	Ring gap (Oil ring)	Z482-E4B D722-E4B D782-E4B	0.15 to 0.35 mm 0.0059 to 0.013 in.	1.20 mm 0.0472 in.
		Z602-E4B D902-E4B	0.15 to 0.35 mm 0.0059 to 0.013 in.	1.20 mm 0.0472 in.
Piston ring groove to piston ring 	Clearance (Second ring)	All models	0.0900 to 0.120 mm 0.00355 to 0.00472 in.	0.15 mm 0.0059 in.
	Clearance (Oil ring)	All models	0.040 to 0.080 mm 0.0016 to 0.0031 in.	0.15 mm 0.0059 in.
Connecting rod 	Alignment	All models	—	0.05 mm 0.002 in.
Crankshaft 	Alignment	All models	—	0.02 mm 0.0008 in.

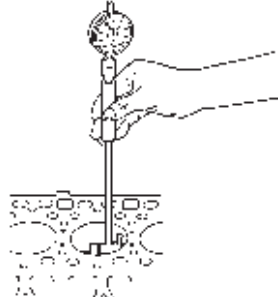

Item		Factory Specification	Allowable Limit	
Crankshaft journal to crankshaft bearing 1 	Oil clearance	All models 0.0340 to 0.106 mm 0.00134 to 0.00417 in.	0.20 mm 0.0079 in.	
	Crankshaft journal O.D.	Z482-E4B D722-E4B D782-E4B	39.934 to 39.950 mm 1.5722 to 1.5728 in.	—
		Z602-E4B D902-E4B	43.934 to 43.950 mm 1.7297 to 1.7303 in.	—
	Crankshaft bearing 1 I.D.	Z482-E4B D722-E4B D782-E4B	39.984 to 40.040 mm 1.5742 to 1.5763 in.	—
		Z602-E4B D902-E4B	43.984 to 44.040 mm 1.7317 to 1.7338 in.	—
	Crankshaft journal to crankshaft bearing 3 (Intermediate) 	Oil clearance	All models 0.028 to 0.059 mm 0.0011 to 0.0023 in.	0.20 mm 0.0079 in.
Crankshaft journal O.D.		Z482-E4B D722-E4B D782-E4B	39.934 to 39.950 mm 1.5722 to 1.5728 in.	—
		Z602-E4B D902-E4B	43.934 to 43.950 mm 1.7297 to 1.7303 in.	—
Crankshaft bearing 3 I.D.		Z482-E4B D722-E4B D782-E4B	39.978 to 39.993 mm 1.5740 to 1.5745 in.	—
		Z602-E4B D902-E4B	43.978 to 43.993 mm 1.7315 to 1.7320 in.	—
Crankshaft journal to crankshaft bearing 2 (Flywheel side) 		Oil clearance	All models 0.028 to 0.059 mm 0.0011 to 0.0023 in.	0.20 mm 0.0079 in.
	Crankshaft journal O.D.	All models 43.934 to 43.950 mm 1.7297 to 1.7303 in.	—	
	Crankshaft bearing 2 I.D.	All models 43.978 to 43.993 mm 1.7315 to 1.7320 in.	—	
Crankpin to crankpin bearing 	Oil clearance	All models 0.020 to 0.051 mm 0.00079 to 0.0020 in.	0.15 mm 0.0059 in.	
	Crankpin O.D.	All models 33.959 to 33.975 mm 1.3370 to 1.3375 in.	—	
	Crankpin bearing I.D.	All models 33.995 to 34.010 mm 1.3384 to 1.3389 in.	—	

Item		Factory Specification	Allowable Limit
Crankshaft 	Side clearance	All models	0.15 to 0.31 mm 0.0059 to 0.012 in.
	Cylinder 	Bore I.D. (Standard size)	Z482-E4B D722-E4B D782-E4B
Z602-E4B D902-E4B			72.000 to 72.019 mm 2.8347 to 2.8353 in.
Bore I.D. (Oversize)		Z482-E4B D722-E4B D782-E4B	67.250 to 67.269 mm 2.6477 to 2.6483 in.
		Z602-E4B D902-E4B	72.250 to 72.269 mm 2.8445 to 2.8452 in.

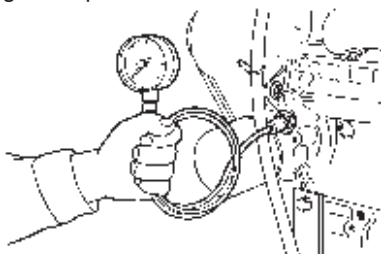
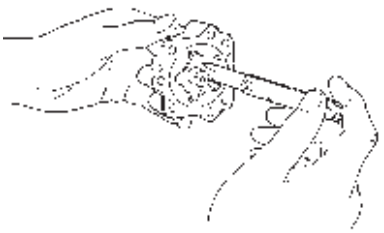
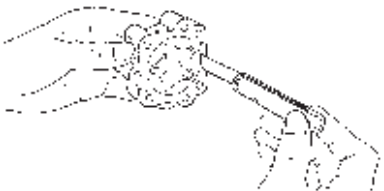
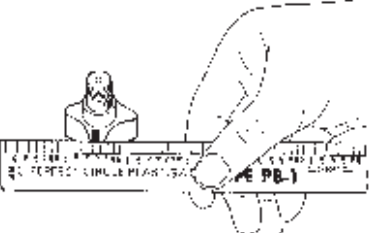

(2) LUBRICATING SYSTEM

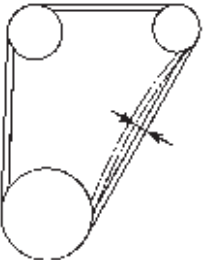
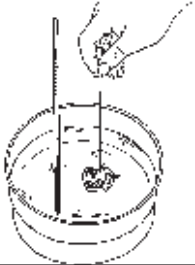
Item		Factory Specification	Allowable Limit
Engine oil pressure 	Engine oil pressure (At idle speed)	All models —	49 kPa 0.50 kgf/cm ² 7.1 psi
	Engine oil pressure (At rated speed)	All models 197 to 441 kPa 2.00 to 4.50 kgf/cm ² 28.5 to 64.0 psi	147 kPa 1.50 kgf/cm ² 21.3 psi
Inner rotor to outer rotor (Oil pump) 	Clearance	All models 0.030 to 0.14 mm 0.0012 to 0.0055 in.	—
Outer rotor to pump body (Oil pump) 	Clearance	All models 0.070 to 0.15 mm 0.0028 to 0.0059 in.	—
Inner rotor to cover (Oil pump) 	Clearance	All models 0.0750 to 0.135 mm 0.00296 to 0.00531 in.	—

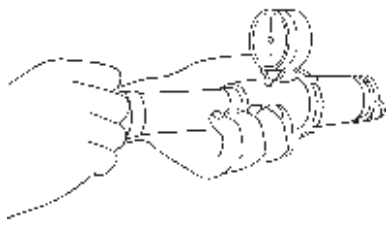
(3) COOLING SYSTEM

Item			Factory Specification	Allowable Limit
Fan belt 	Tension	All models	7.0 to 9.0 mm (0.28 to 0.35 in.) deflection at 98 N (10 kgf, 22 lbf) of force	—
Thermostat 	Valve opening temperature (At beginning)	All models	69.5 to 72.5 °C 157.1 to 162.5 °F	—
	Valve opening temperature (Opened completely)	All models	85 °C 185 °F	—
Radiator 	Water tightness	All models	No leak at specified pressure	—
Radiator cap 	Pressure falling time	All models	10 seconds or more for pressure falling 90 → 60 kPa (0.90 → 0.60 kgf/cm ² , 10 → 9 psi)	—

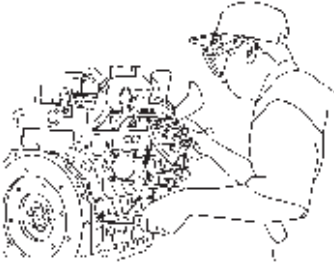
(4) FUEL SYSTEM

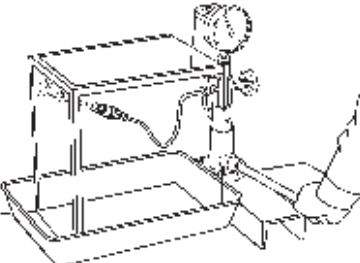
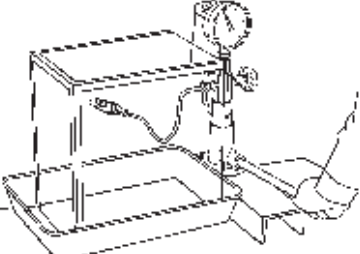
Item		Factory Specification	Allowable Limit	
Injection pump 	Injection timing	Z482-E4B D602-E4B (3600 min ⁻¹ (rpm))	0.3186 to 0.3447 rad (18.25 to 19.75°) before T.D.C.	—
		D722-E4B (3600 min ⁻¹ (rpm))	0.3360 to 0.3621 rad (19.25 to 20.75°) before T.D.C.	—
		D782-E4B (3200 min ⁻¹ (rpm))	0.2837 to 0.3097 rad (16.25 to 17.75°) before T.D.C.	—
		D902-E4B (3600 min ⁻¹ (rpm))	0.3186 to 0.3447 rad (18.25 to 19.75°) before T.D.C.	—
Pump element 	Fuel Tightness	All models	—	13.73 MPa 140.0 kgf/cm ² 1991 psi
Delivery valve 	Fuel Tightness	All models	10 seconds 13.73 → 12.75 MPa 140.0 → 130.0 kgf/cm ² 1991 → 1849 psi	5 seconds 13.73 → 12.75 MPa 140.0 → 130.0 kgf/cm ² 1991 → 1849 psi
Injection nozzle 	Injection pressure	All models	13.73 to 14.70 MPa 140.0 to 150.0 kgf/cm ² 1992 to 2133 psi	—
Injection nozzle 	Valve seat tightness	All models	No fuel leak at 12.75 MPa 130.0 kgf/cm ² 1849 psi	—

(5) ELECTRICAL SYSTEM

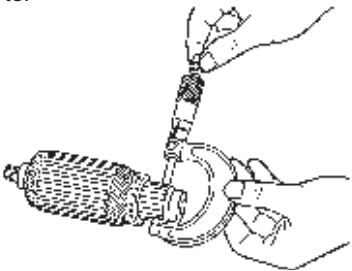
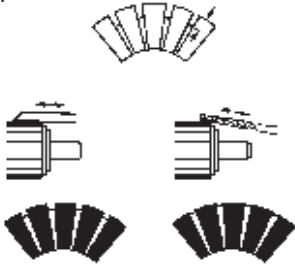
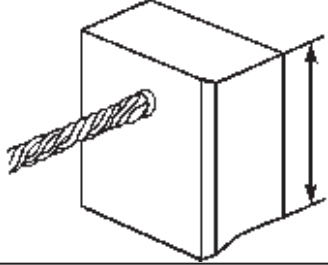
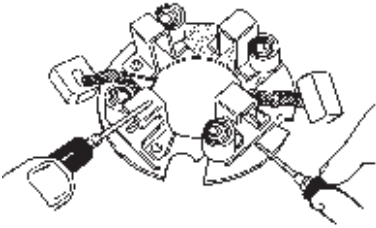
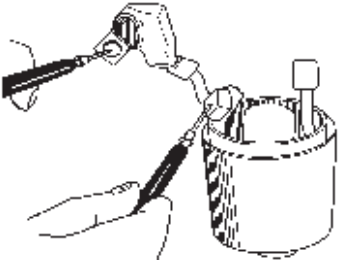
Item		Factory Specification	Allowable Limit	
Starter 	Commutator O.D.	Electromagnetic drive type	28.0 mm 1.10 in.	27.0 mm 1.06 in.
		Planetary gear reduction type	30.0 mm 1.18 in.	29.0 mm 1.14 in.
	Difference of commutator O.D's	Electromagnetic drive type	Less than 0.05 mm 0.002 in.	0.40 mm 0.016 in.
		Planetary gear reduction type	Less than 0.02 mm 0.0008 in.	0.05 mm 0.002 in.
Starter 	Mica under cut	All models	0.50 to 0.80 mm 0.020 to 0.031 in.	0.20 mm 0.0079 in.
Starter 	Brush length	Electromagnetic drive type	16.0 mm 0.630 in.	10.5 mm 0.413 in.
		Planetary gear reduction type	14.0 mm 0.551 in.	9.0 mm 0.35 in.
Starter 	Brush holder resistance (Brush holder - Holder support)	All models	Infinity	—
Starter 	Field coil resistance (Lead - Brush)	All models	Continuity	—

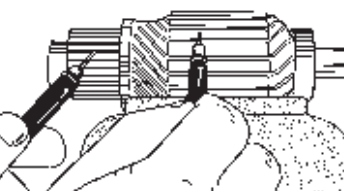
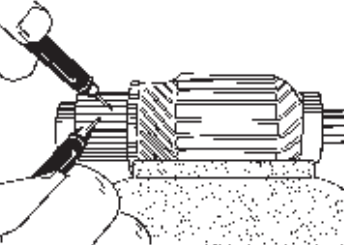
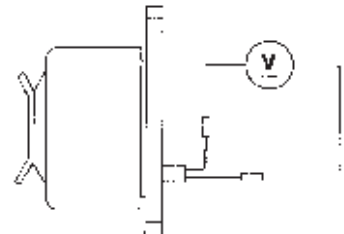
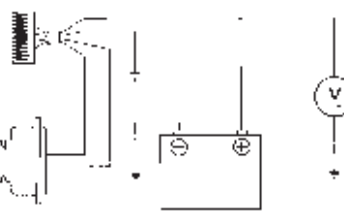
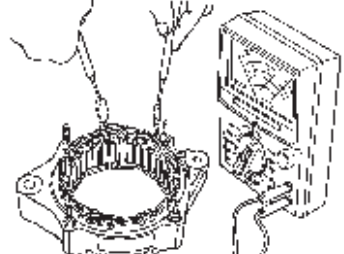
Item			Factory Specification	Allowable Limit
Starter 	Field coil resistance (Brush - Yoke)	All models	Infinity	—
Starter 	Armature coil resistance (Commutator - Armature coil core)	All models	Infinity	—
Starter 	Armature coil resistance (Segment - Segment)	All models	Continuity	—
Dynamo 	No-load output	All models	AC 20V or more at 5200 min ⁻¹ (rpm)	—
Dynamo 	Regulating voltage	All models	14 to 15 V at 5200 min ⁻¹ (rpm)	—
Alternator 	Stator resistance	All models	Less than 1.0 Ω	—

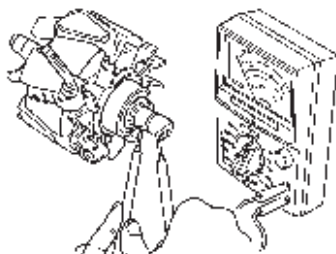
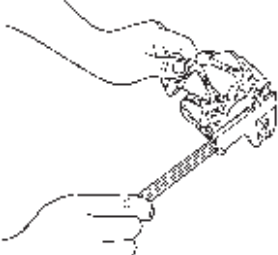
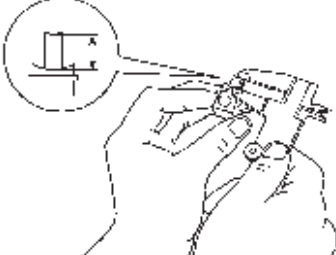
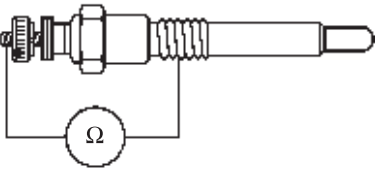
Item			Factory Specification	Allowable Limit
Alternator 	Rotor resistance	All models	2.9 Ω	—
Alternator 	Slip ring O.D.	All models	14.4 mm 0.567 in.	14.0 mm 0.551 in.
Alternator 	Brush length	All models	10.0 mm 0.394 in.	8.4 mm 0.33 in.
Glow plug 	Resistance	All models	Approx. 0.9 Ω	—

TIGHTENING TORQUES

(1) Special Tightening Torques

For "*" marked screws, bolts and nuts on under table, apply engine oil to their threads and seats before tightening.

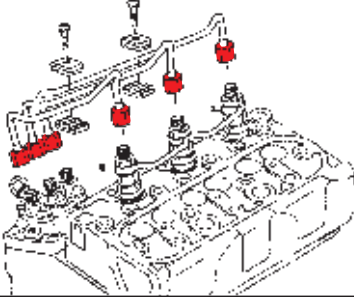
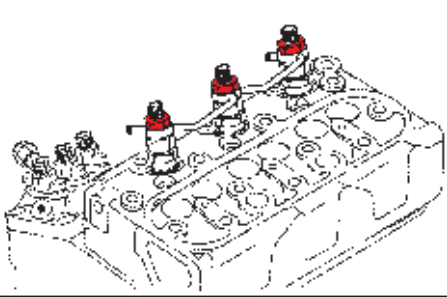
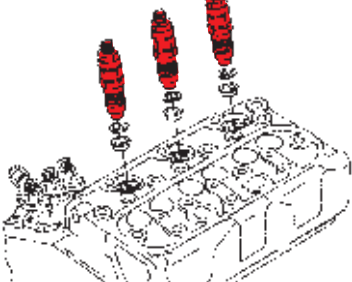
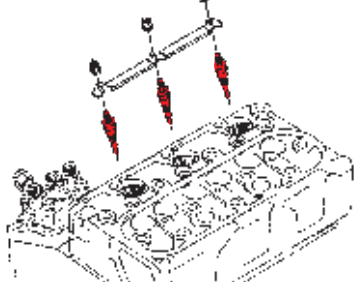
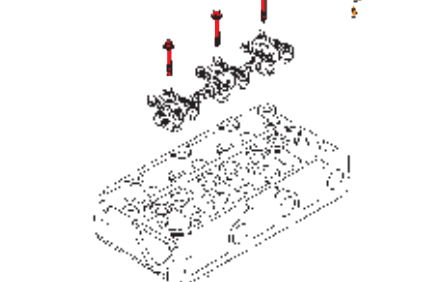
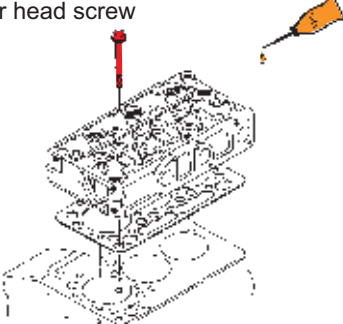
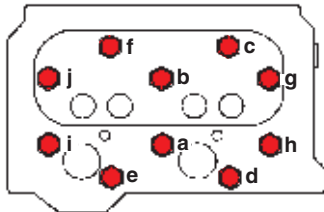
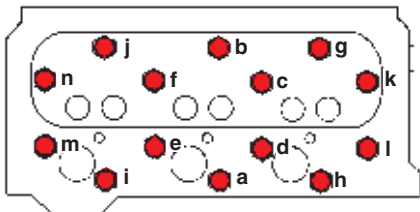
<p>Cylinder head cover screw</p> 		<p>Injection pipe retaining nut</p> 		<p>Overflow pipe retaining nut</p> 	
Z482-E4B		Z482-E4B		Z482-E4B	
Z602-E4B	6.87 to 11.2 N·m	Z602-E4B	25 to 34 N·m	Z602-E4B	20 to 24 N·m
D722-E4B	0.700 to 1.15 kgf·m	D722-E4B	2.5 to 3.5 kgf·m	D722-E4B	2.0 to 2.5 kgf·m
D782-E4B	5.07 to 8.31 lbf·ft	D782-E4B	18 to 25 lbf·ft	D782-E4B	15 to 18 lbf·ft
D902-E4B		D902-E4B		D902-E4B	
<p>Nozzle holder assembly</p> 		<p>Glow plug</p> 		<p>Rocker arm bracket screw</p> 	
Z482-E4B		Z482-E4B		Z482-E4B	
Z602-E4B	49 to 68 N·m	Z602-E4B	7.9 to 14 N·m	Z602-E4B	9.81 to 11.2 N·m
D722-E4B	5.0 to 7.0 kgf·m	D722-E4B	0.80 to 1.5 kgf·m	D722-E4B	1.00 to 1.15 kgf·m
D782-E4B	37 to 50 lbf·ft	D782-E4B	5.8 to 10 lbf·ft	D782-E4B	7.24 to 8.31 lbf·ft
D902-E4B		D902-E4B		D902-E4B	
<p>Cylinder head screw</p> 		<p>Cylinder head tightening order</p> <p>(A) 2 cylinder model</p>  <p>(B) 3 cylinder model</p> 			
Z482-E4B		<p>(A) 2 cylinder model a → j</p> <p>(B) 3 cylinder model a → n</p>			
Z602-E4B	38 to 42 N·m				
D722-E4B	3.8 to 4.3 kgf·m				
D782-E4B	28 to 31 lbf·ft				
D902-E4B					

Fan drive pulley screw

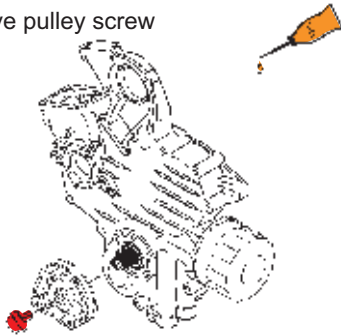

Z482-E4B	
Z602-E4B	118 to 127 N·m
D722-E4B	12.0 to 13.0 kgf·m
D782-E4B	86.8 to 94.0 lbf·ft
D902-E4B	

Gear case screw

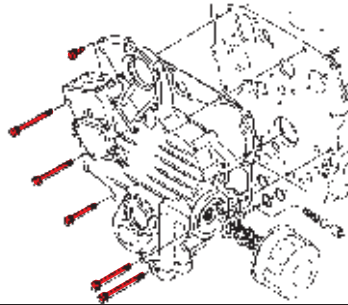

Z482-E4B	
Z602-E4B	9.81 to 11.2 N·m
D722-E4B	1.00 to 1.15 kgf·m
D782-E4B	7.24 to 8.31 lbf·ft
D902-E4B	

Idle gear shaft mounting screw

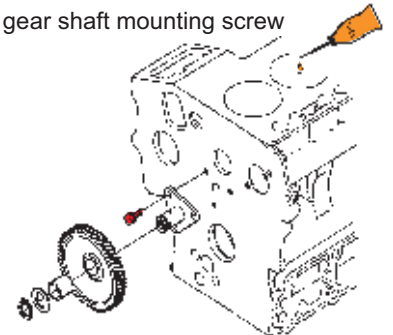

Z482-E4B	
Z602-E4B	9.81 to 11.2 N·m
D722-E4B	1.00 to 1.15 kgf·m
D782-E4B	7.24 to 8.31 lbf·ft
D902-E4B	

Camshaft set screw

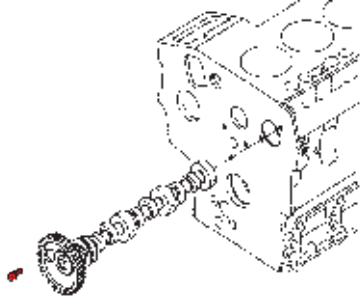

Z482-E4B	
Z602-E4B	9.81 to 11.2 N·m
D722-E4B	1.00 to 1.15 kgf·m
D782-E4B	7.24 to 8.31 lbf·ft
D902-E4B	

Fuel camshaft set screw & Governor forklever set screw

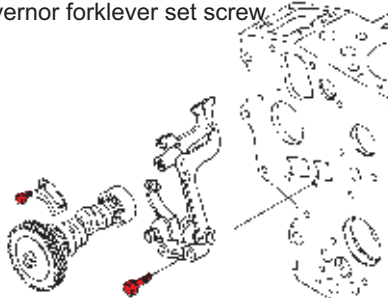

Z482-E4B	
Z602-E4B	9.81 to 11.2 N·m
D722-E4B	1.00 to 1.15 kgf·m
D782-E4B	7.24 to 8.31 lbf·ft
D902-E4B	

Connecting rod screw

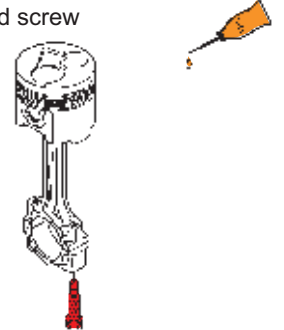

Z482-E4B	
Z602-E4B	27 to 30 N·m
D722-E4B	2.7 to 3.1 kgf·m
D782-E4B	20 to 22 lbf·ft
D902-E4B	

Flywheel screw

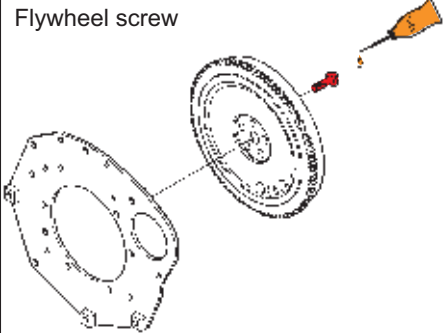

Z482-E4B	
Z602-E4B	54 to 58 N·m
D722-E4B	5.5 to 6.0 kgf·m
D782-E4B	40 to 43 lbf·ft
D902-E4B	

Bearing case cover mounting screw

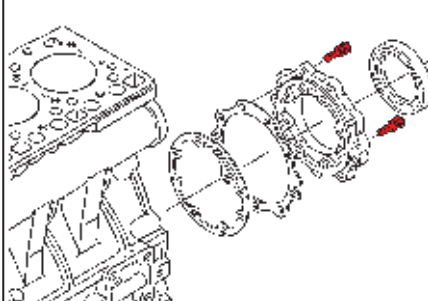

Z482-E4B	
Z602-E4B	9.81 to 11.2 N·m
D722-E4B	1.00 to 1.15 kgf·m
D782-E4B	7.24 to 8.31 lbf·ft
D902-E4B	

Main bearing case screw 1

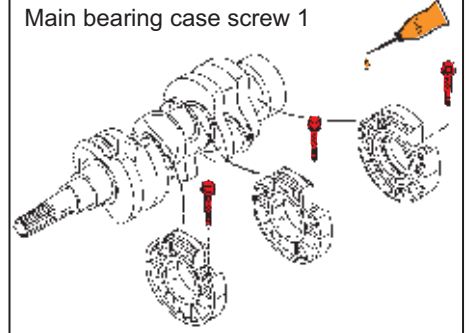

Z482-E4B	
Z602-E4B	13 to 15 N·m
D722-E4B	1.3 to 1.6 kgf·m
D782-E4B	9.4 to 11 lbf·ft
D902-E4B	

Main bearing case screw 2

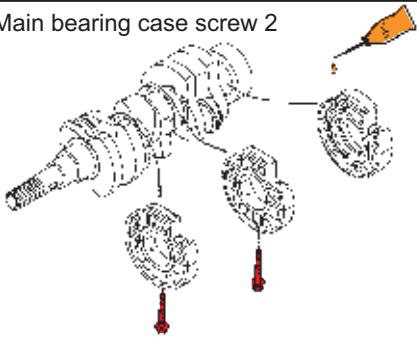

Z482-E4B	
Z602-E4B	27 to 30 N·m
D722-E4B	2.7 to 3.1 kgf·m
D782-E4B	20 to 22 lbf·ft
D902-E4B	

Nozzle holder



Z482-E4B	
Z602-E4B	35 to 39 N·m
D722-E4B	3.5 to 4.0 kgf·m
D782-E4B	26 to 28 lbf·ft
D902-E4B	

Oil pressure switch

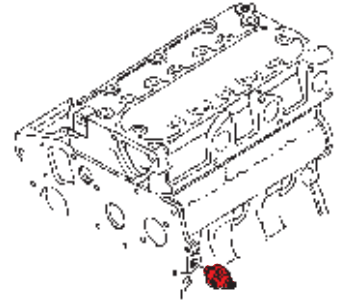

Z482-E4B	
Z602-E4B	15 to 19 N·m
D722-E4B	1.5 to 2.0 kgf·m
D782-E4B	11 to 14 lbf·ft
D902-E4B	

Starter (B terminal nut)

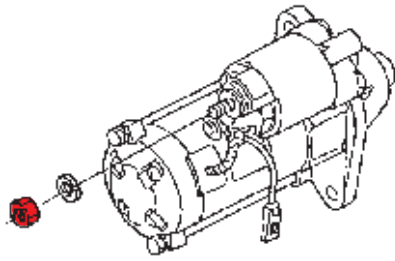

Z482-E4B	
Z602-E4B	5.9 to 11 N·m
D722-E4B	0.60 to 1.2 kgf·m
D782-E4B	4.4 to 8.6 lbf·ft
D902-E4B	

Alternator pulley nut

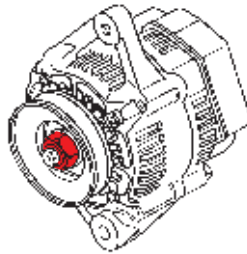

Z482-E4B	
Z602-E4B	58.4 to 78.9 N·m
D722-E4B	5.95 to 8.05 kgf·m
D782-E4B	43.1 to 58.2 lbf·ft
D902-E4B	

Drain plug with copper gasket (M12 x 1.25)

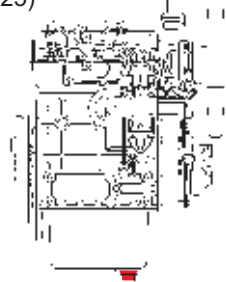

Z482-E4B	
Z602-E4B	33 to 37 N·m
D722-E4B	3.3 to 3.8 kgf·m
D782-E4B	24 to 27 lbf·ft
D902-E4B	

Drain plug with copper gasket (M22 x 1.5)

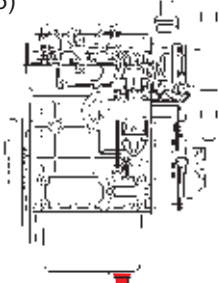

Z482-E4B	
Z602-E4B	64 to 73 N·m
D722-E4B	6.5 to 7.5 kgf·m
D782-E4B	47 to 54 lbf·ft
D902-E4B	

Drain plug with rubber coated gasket (M22 x 1.5)

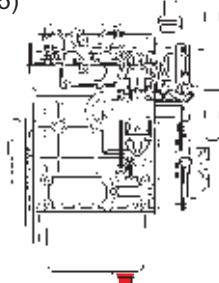

Z482-E4B	
Z602-E4B	45 to 53 N·m
D722-E4B	4.5 to 5.5 kgf·m
D782-E4B	33 to 39 lbf·ft
D902-E4B	

(2) General Tightening Torques

Screw and bolt material grades are shown by numbers punched on the screw and bolt heads.

Prior to tightening, be sure to check out the numbers as shown below.

None or 4 : Standard grade

7 : Special grade

Nominal Diameter	Standard Grade	Special Grade
M6	7.9 to 9.3 N·m 0.80 to 0.95 kgf·m 5.8 to 6.8 lbf·ft	9.81 to 11.2 N·m 1.00 to 1.15 kgf·m 7.24 to 8.31 lbf·ft
M8	18 to 20 N·m 1.8 to 2.1 kgf·m 13 to 15 lbf·ft	24 to 27 N·m 2.4 to 2.8 kgf·m 18 to 20 lbf·ft
M10	40 to 45 N·m 4.0 to 4.6 kgf·m 29 to 33 lbf·ft	48 to 55 N·m 4.9 to 5.7 kgf·m 36 to 41 lbf·ft
M12	63 to 72 N·m 6.4 to 7.4 kgf·m 47 to 53 lbf·ft	78 to 90 N·m 7.9 to 9.2 kgf·m 58 to 66 lbf·ft